

Submersible pumps

Type IMM 71



Usages:

The pumps are suitable to transfer liquids containing impurities measuring up to 2-3 mm. The hydraulic components, namely the brass impeller, the scroll and the aluminium pump body allow the pumps to be used with water, emulsions and oily substances in general with a maximum viscosity of 3° Engler (21 CST).

The temperature of the liquid must not exceed 90° C.

They are usually used on:

- Machine tools** (milling machines – lathes - drills)
- Glass processing machines** (TRI version)
- Surface treatment systems** (version in cast iron)*
- Filtration systems**
- Air-conditioning systems.**

They should usually be installed on a tank, with a capacity in proportion to the flow rate, at about 4 – 5 cm. from the bottom. It is important to check that the maximum level of the liquid in the tank always remains 3 – 4 cm. lower than the flange (see figure).

In cases where the liquid is particularly dirty, the user is recommended to construct the tank in compartments to allow the dirt to deposit before it is stirred up by the pump.

For other usages you are advised to consult our technical office.

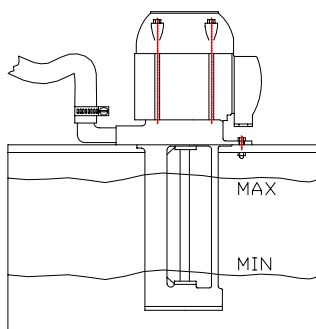
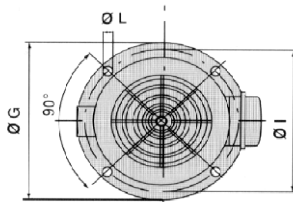
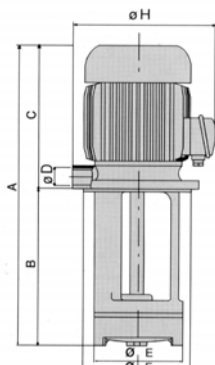

Table of dimensions and weights

TYPE	A mm	B mm	C mm	ØD mm	ØE mm	ØF mm	ØG mm	H mm	ØI mm	ØL mm	Kg.
IMM 71 A	440	200	240	1 "	190	-	230	225	204	9 N. 5	10,5
	490	250									11
	565	325*									11,5
	680	440									12
IMM 71 B	440	200	240	1 "	190	-	230	225	204	9 N. 5	11
	490	250									11,5
	565	325*									12
	680	440									12,5

*On request cast iron pump body

Electrical features

Type	KW. Input	Hz. 50		Hz. 60			
		230/400	254-290/440-500	230/400	208-230/440-460	254-290/440-500	318-346/550-600
IMM 71 A	0,53	2,7/1,6	2,1/1,2	3,2/1,8	3,1/1,8	2,7/1,6	2,3/1,3
IMM 71 B	0,78	3,3/1,9	2,6/1,5	4,0/2,3	3,6/2,1	3,3/1,9	2,8/1,6

